

Quadrant[®]

VALVE & ACTUATOR, LLC



SERIES 3W-SS & 4W-SS

3 and 4-Way, 4-Seated Multiport Ball Valves



Series 3W-SS & 4W-SS 3 and 4-Way 4-Seated Multiport Ball Valves

1/4" to 2" Sizes, 1000WOG

FEATURES

- 3 or 4-Way construction
- 4-Seated design provides 1000PSI operating pressure
- Live-loaded stem packing automatically compensates for stem packing wear and/or temperature variations
- Direct mounting of ISO 5211 compliant actuators
- Dual ISO 5211 mounting patterns
- Square stem head design
- Standard stainless handle and lock plate
- "L" port, "T" port and "X" port ball patterns available

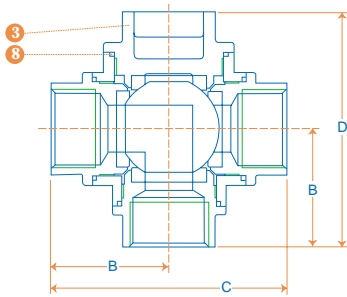

3-Way Top View

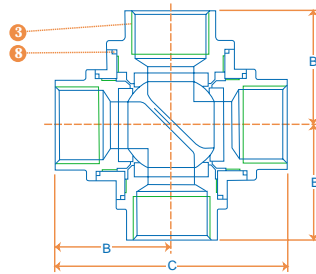

4-Way Top View

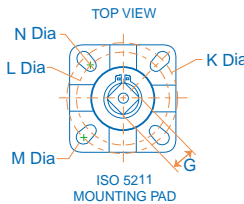
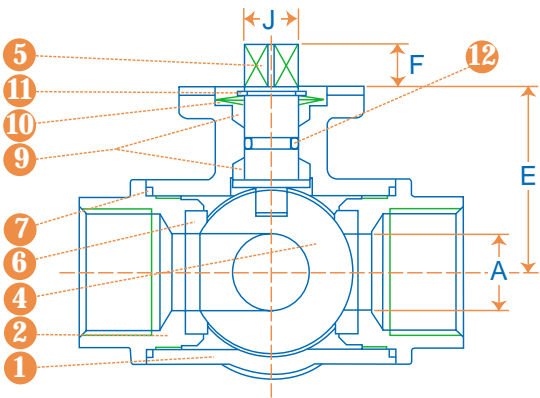

RATINGS

1000PSIG @ 100°F
150PSIG Saturated Steam

MATERIALS OF CONSTRUCTION (STD)

PART	QTY.	DESCRIPTION	STANDARD MATERIAL
1	1	BODY	ASTM A351 GR. CF8M
2	3	TAILPIECE	ASTM A351 GR. CF8M
3	1	TAILPIECE A	ASTM A351 GR. CF8M
4	1	BALL	ASTM A351 GR. CF8M
5	1	STEM	ASTM A276 GR 316
6	4	SEAT	PTFE
7	3	TAILPIECE SEAL	PTFE
8	1	TAILPIECE A SEAL	PTFE
9	2	STEM PACKING	R-PTFE
10	2	BELLEVILLE WASHERS	304SS
11	1	RETAINING RING	420SS
12	1	O-RING	VITON
13	1	HANDLE	ASTM A351 GR. CF8M
NOT SHOWN	1	HANDLE BOLT	304SS
NOT SHOWN	1	STOP PLATE	304SS

DIMENSIONS, WEIGHTS, CV FACTORS & MAXIMUM OPERATING TORQUE

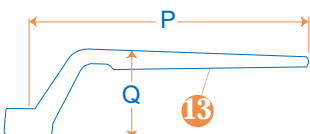

Handle Dimensions

SIZE	A	B	C	D	E	F	G	J DIA	K DIA	L DIA	M DIA	N DIA	P	Q	ISO PATTERN(S)	WEIGHT (LBS)	MAX TORQUE (IN-LB)
1/4" - 3/8"	0.50	1.48	2.96	2.78	1.56	0.35	9MM	0.47	1.65	1.42	0.24	.024	4.6	1.5	F03 & F04	1.6	60
1/2"	0.50	1.48	2.96	2.78	1.56	0.35	9MM	0.47	1.65	1.42	0.24	0.24	4.6	1.5	F03 & F04	1.6	60
3/4"	0.63	1.68	3.36	3.21	1.69	0.35	9MM	0.47	1.65	1.42	0.24	0.24	4.6	1.5	F03 & F04	2.6	80
1"	0.79	1.97	3.94	3.96	1.87	0.43	11MM	0.55	1.97	1.65	0.28	0.24	5.7	1.9	F04 & F05	4.1	130
1-1/4"	0.98	2.27	4.54	4.35	2.09	0.43	11MM	0.55	1.97	1.65	0.28	0.24	5.7	1.9	F04 & F05	5.8	190
1-1/2"	1.26	2.48	4.96	4.80	2.42	0.55	14MM	0.71	2.76	1.97	0.36	0.28	6.2	2.1	F05 & F07	8.5	280
2"	1.50	2.92	5.84	5.30	2.76	0.55	14MM	0.71	2.76	1.97	0.36	0.28	6.2	2.1	F05 & F07	12.9	450



Series 3W-SS & 4W-SS 3 and 4-Way 4-Seated Multiport Ball Valves
1/4" to 2" Sizes, 1000WOG

" L " PORT POSITIONS

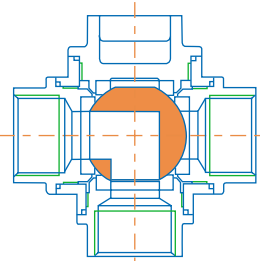

Position #1

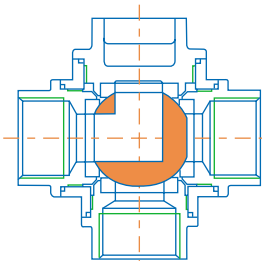

Position #2

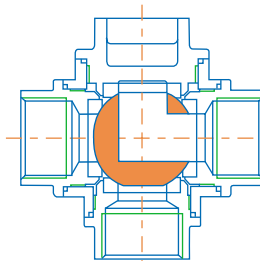

Position #3

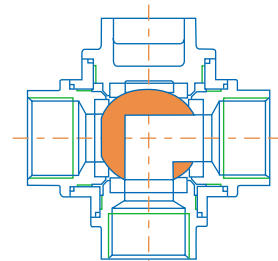

Position #4

" T " PORT POSITIONS

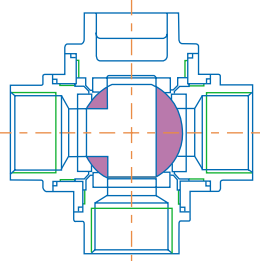

Position #1

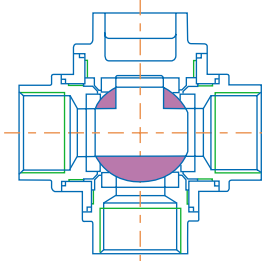

Position #2

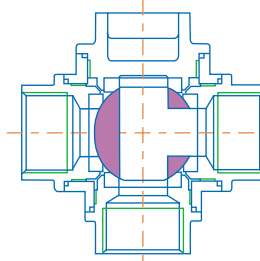

Position #3

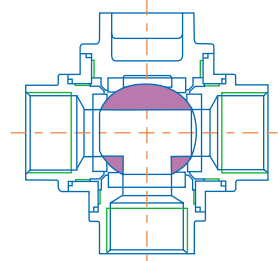

Position #4

" X " PORT POSITIONS

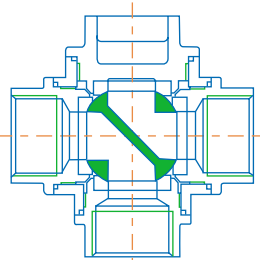

Position #1

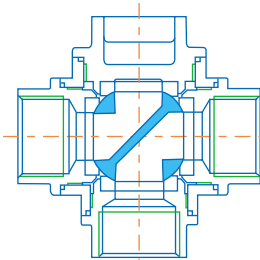

Position #2

NOTE:
Handle can be fitted to provide 90° rotation or 360° rotation. If 90° rotation is selected, valve can be moved between any (2) adjacent positions.

Example:
Position 1&2;
2&3; 3&4; or
4&1.

Cv FACTORS

SIZE	"L" Port (Angle Flow)	"T" Port (Angle Flow)	"T" Port (Thru)	"X" Port (Angle Flow)
1/4"	2.0	1.5	5.0	2.0
3/8"	3.0	2.5	8.0	2.5
1/2"	4.0	3.5	11.0	3.0
3/4"	10.0	8.0	18.0	9.0
1"	16.0	14.0	36.0	14.0
1-1/4"	25.0	22.0	44.0	22.0
1-1/2"	40.0	34.0	70.0	36.0
2"	58.0	49.0	105.0	50.0

R-PTFE SEATS

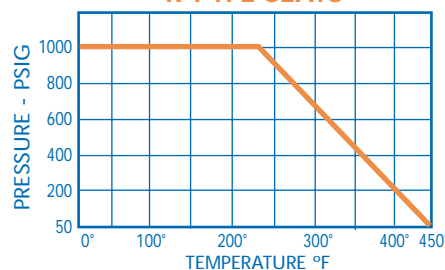

Quadrant[®]

VALVE & ACTUATOR, LLC

SERIES 3W-SS & 4W-SS

NUMBERING SYSTEM ... HOW TO ORDER:

3T R S S R R LH TT 100

SERIES	PORT SIZE	BODY & TAILPIECE MATERIAL	BALL/STEM MAT'L	SEAT MAT'L	SEAL MAT'L	HANDLE TYPE	ENDS	SIZE
	F = FULL (1/4"-1/2") R = REDUCED	S = CF8M A = CN7M (Alloy 20) D = Duplex SS	S = 316SS A = ALLOY 20 D = DUPLEX	V = Virgin PTFE R = Reinforced PTFE P = PEEK J = CAVITY FILL PTFE	V = Virgin PTFE R = Reinforced PTFE	LH = SS LOCKING HANDLE BS = NO HANDLE XH = EXTENDED HANDLE PA = DOUBLE ACTING PNEUMATIC SA = SPRING RETURN EA = 115VAC ELECTRIC ACTUATED	TT = FNPT WW = SOCKET WELD 1F = CLASS 150 FLANGED	025 = 1/4" 038 = 3/8" 050 = 1/2" 075 = 3/4" 100 = 1" 125 = 1-1/4" 150 = 1-1/2" 200 = 2"
3L = 3-Way L-Port 3T = 3-Way T-Port 4L = 4-Way L-Port 4T = 4-Way T-Port 4X = 4-Way X-Port								



Series 3L with
Quadrant C-Series Actuator

Quadrant TB-SS
3-Way Stainless Steel
Diverter Valve



Quadrant TW-BP
3-Way Bronze
Diverter Valve