

PRECISION INSTRUMENT COMPANY

BIMETAL THERMOMETER ADJUSTABLE ANGLE TYPE 'BxAx'

STANDARD FEATURES

- All Stainless Construction
- With Glass Lens
- Anti-Parallax Dial
- Vibration Resistant (Reduced Needle Flutter)
- Fast Response To Temperature Change
- Hermetically Sealed (Moisture Proof)
- +/- 1 % Full Scale Accuracy
- Stem Welded To Connection



PART NUMBER*	STEM LENGTH*
B5A2	2 1/2"
B5A4	4"
B5A6	6"
B5A9	9"
B5A12	12"
B5A15	15"
B5A18	18"
B5A24	24"
* For 3" Dial Size change 'B5A' to 'B3A'	

STANDARD RANGES*	
CODE	RANGE
AA	-40/120 F & C
BB	-40/160 F & C
EE	0/150 F & C
GG	0/200 F & C
JJ	20/240 F & C
II	0/250 F & C
MM	50/300 F & C
PP	50/400 F & C
RR	50/550 F & C
SS	150/750 F & C
TT	200/1000 F & C

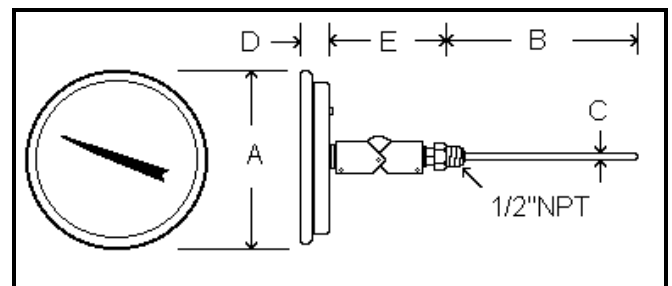
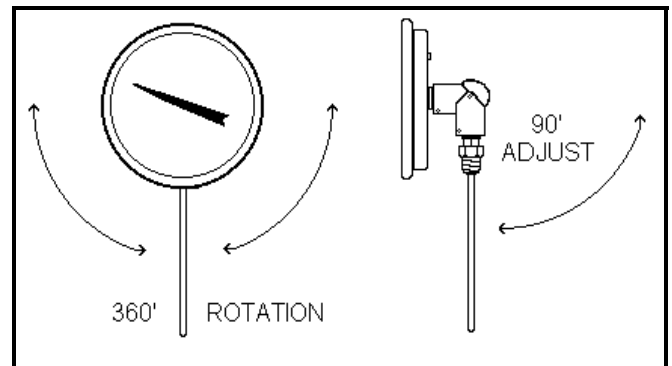

*NOTE:

- 1.) Other ranges, stem lengths and configurations are available upon request.
- 2.) Thermowells of all types and materials of construction available also
- 3.) Please call with any inquiries.

Dial		A	B	C	D	E
5"	IN.	5.13"	STEM LENGTH	1/4"	.67"	3.3"
	MM	130.39	STEM LENGTH	6.45	16.95	83.87
3"	IN.	3.13"	STEM LENGTH	1/4"	.67"	3.3"
	MM	78	STEM LENGTH	6.45	16.95	83.87